



PowerLINE® RG15/UG15



Setting the highest operational and environmental standards.

FuelWise



PowerLINE® generator sets. Rugged, reliable, and environmentally responsible.

Carrier PowerLINE® generator sets offer a new diesel engine that exceeds the latest U.S. Environmental Protection Agency (EPA) particulate matter emission requirements by nearly 30% and is available with the FuelWise™ option that, under certain conditions, can reduce fuel consumption – and the unit's carbon footprint – by up to 28%.

The power to conserve.

With Carrier's Eco-DrivenSM FuelWise option, the generator set can operate in two modes: economy or power. In economy mode, the generator set starts in high speed and then automatically switches over to a fuel-conserving low speed for the duration of the trip. The two speeds correspond to 60Hz and 50Hz operations, compliant with the ISO 1496 specifications for container refrigeration units. Carrier laboratory tests confirm fuel savings of up to 26%–28% operating in economy mode (depending on reefer unit, load, and ambient condition). For applications such as hot loads through tropical environments where pull-down times are critical, switching to power mode allows the unit to run in continuous high-speed operation until the desired setpoint is reached, to help ensure fastest pull-down time.



Power you'll get attached to.

Industry-leading PowerLINE RG15 clip and UG15 undermount generator sets from Carrier Transicold are designed and built for one purpose: continuous, unattended operation for all refrigerated containers transported by road or rail. PowerLINE generator sets offer the ideal combination of horsepower, torque, and motor-starting capability.

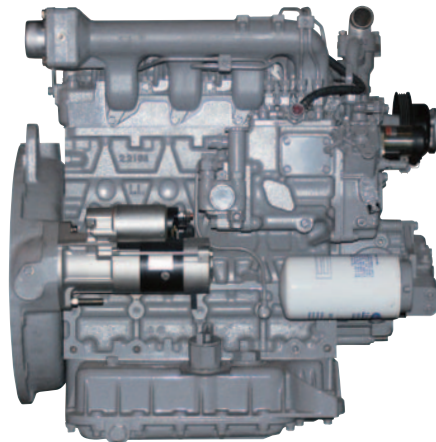

V2203-DI engine is EPA-certified.

Power to start any reefer, anywhere.

The Carrier-designed EPA-certified, low-emission engine is built specially to handle rugged generator set applications. The new technologically advanced V2203-DI direct-injection engine delivers green, clean, dependable power and drives particulate emissions down to 0.214 g/kWh – the lowest in the industry, 30% below what is required by the EPA Tier 4 interim (Tier 4i) standard and 20% lower than some competitive units with Tier 4i engines. Put into perspective, a fleet running 250

generator sets with Carrier's Tier 4i engine will emit 1,575 kg fewer particulates over the typical life of the unit than an identical fleet using competitive Tier 4i units. The V2203-DI engine is EPA Tier 4i-certified for 1,800 rpm with multi-speed. Rated at 23.9kW (32 hp), the V2203-DI includes an electronic governor system that provides near-constant engine speed, which results in more stable voltage output. The need for field speed adjustment is eliminated, and startup capability is improved in high ambient conditions.

One powerful generator.

Carrier's powerful, reliable, low-maintenance PowerLINE generator produces 460 volts of continuous power for uninterrupted protection. Designed for high inductive loads and superior motor-starting capability, Carrier's direct-drive brushless generator features an internally excited, self-regulated design. All electrical components are enclosed within the generator package. Wet-wound, thermo-setting epoxy is applied to each copper winding turn, significantly reducing air gaps. Polystator coating offers superior resistance to moisture and salt.



Brushless, self-regulated design produces 460 volts, 18kVA, 15kW @ 0.8 pf.

Reliable, global support.

Experienced people and dependable worldwide support have made Carrier generator power the first choice of more shipping lines and major generator set equipment users supplying the world market.

SAFE AND SECURE MOUNTING: CLIP



Clamp-style



Header pin

UNDERMOUNT



Standard clamp



QuickMount™ bracket

Reduce operating costs.

You'll appreciate these additional system advancements.

- The Carrier spin-on oil filter with internal bypass filtration is now standard and extends service intervals to 3,000 hours or one year, whichever comes first.
- An external in-line fuel strainer with clear bowl strains larger particles in fuel prior to entering the lift pump. The clear bowl allows visual inspection of the screen for clogging.
- Self-tensioning, flexible, Poly V belt eliminates the need for an idler pulley and the guesswork associated with manual tensioning. No more removing panels to access and adjust the idler. However, checks for belt integrity should be performed regularly. The optimum tension provided by the belt helps assure maximum life of the water pump bearing. The elimination of loose belt conditions helps assure maximum cooling capability of the fan and cooling system. The Poly V belt's profile helps extend belt life beyond that of conventional belts, minimizing the cost of belt replacement.
- Dry element, "cartridge"-style air filter is now a standard offering. The filter-minder allows for quick visual check of filter condition and will signal

when cartridge must be replaced. Servicing takes a fraction of the time compared to oil bath, and the need for disposal of contaminated oil is eliminated.

- PowerLINE UG main door opening has been increased substantially and a battery door added for ease of access. This is key to certain applications where units need to be serviced on-chassis.



50% larger service opening improves access, reduces service time.

So easy to start.

Fast, sure starting puts your operator in complete control. The PowerLINE Start/Stop switch is mounted low in front, within easy reach. Analog instrumentation is easy to read to confirm output. The in-air intake manifold heater allows for fast starting and trouble-free operation even at low ambient temperatures.



Control box with easy-to-read gauges.

So easy to operate.

Outstanding convenience and safety make PowerLINE number one for operating control. Up-front analog instrumentation is easy to read and gives you immediate access to key operating parameters. The control system is uncomplicated, easy to access and troubleshoot. And the electrical receptacle is located within easy reach on the front panel (25-amp main safety switch cuts power when connecting or disconnecting the power cord).



Safe, easy power cord connection.

So easy to attach.

Whether you choose clip or undermount, PowerLINE gives you more mounting flexibility. Attaching and disconnecting the generator set takes just minutes.

- For clip mounting, our pin-mounting bracket design saves time.
- For clamp mounting, our self-aligning ratcheted clamp locks allow safe, secure attachment to corner castings.
- For undermount, you can choose standard four-point mounting or our exclusive QuickMount™ design.

PERFORMANCE SPECIFICATIONS

PowerLINE

RG15 Clip

Specifications are subject to change without notice.

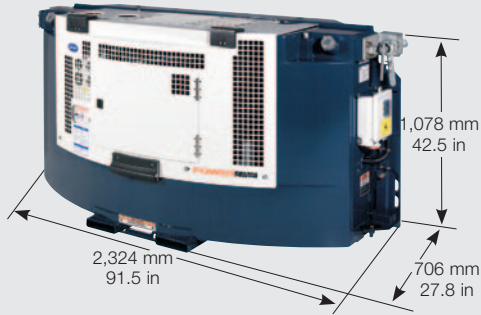

Standard Features Include:

- V2203-DI 4-cylinder, water-cooled, 2.2-liter direct-injection diesel engine
- Nominal 15 kW brushless, self-regulated generator, 460V output
- 130-gallon (492-liter) fuel tank
- Pin-mount system
- High-efficiency air cleaner (standard dry element, optional oil bath)
- Full-flow spin-on oil filter with internal bypass
- Integral fuel filter with water separator
- Fuel warmer
- Stainless steel hardware
- Low-mounted controls
- Large aluminum service access door with self-locking/quick-release latch
- Enclosed forklift pockets
- 12V DC maintenance-free battery
- Safety stop controls for low oil pressure, high water temperature
- Frame and sheet metal components powder-coated for durability
- Patented E-coat tube and fin radiator
- Large oil pan capacity extends running hours between oil changes

- Fuel gauge, color-coded for easy level identification from a distance
- Oil pressure and water temperature gauges
- DC ammeter
- Shipping bumpers
- Power output circuit breaker
- Preheat and Start/Run/Off switches
- Engine hourmeter
- Solid-state battery charger
- Operating instruction labels (English and Spanish)
- Maintenance and schematic labels
- 460V receptacle with spring-loaded cap

Accessories and Options:

- FuelWise
- Auto Restart
- Clamp-mount system or provision for clamp mount
- 102-gallon (386-liter) fuel tank
- CE certification
- TIR seals for detecting unauthorized access

Approximate Weight:

830 kg (1,830 lb.), less fuel

UG15 Undermount

Specifications are subject to change without notice.

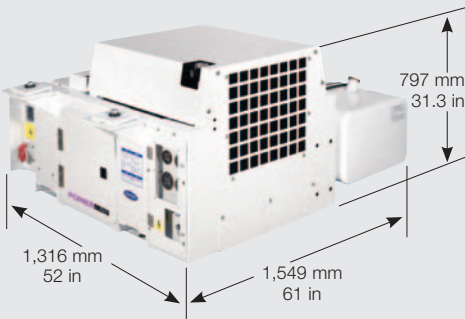

Fuel tank lengths:

- 50 gal (189 L) = 1,143 mm (45.0 in)
- 68 gal (257.5 L) = 1,485 mm (58.5 in)
- 80 gal (303 L) = 1,632 mm (64.3 in)

RG and UG Warranty:

Within two years after the date of shipment from the manufacturer's plant or 27 months from the manufactured date, whichever comes first, Carrier Transicold Division, through designated Container Service Centers, will, at Carrier Transicold's option, repair or replace, with a new or remanufactured part, any parts or components of the products identified above which UNDER NORMAL USE AND SERVICE malfunction as a result of defects in material or workmanship. The warranty terms and limitations are listed in Form 62-10185. Consult your Carrier Transicold representative for complete warranty details.

Standard Features Include:

- V2203-DI 4-cylinder, water-cooled, 2.2-liter direct-injection diesel engine
- Nominal 15 kW brushless, self-regulated generator, 460V output
- All-steel fabricated frame construction with four-point PlateMount system
- High-efficiency air cleaner (standard dry element, optional oil bath)
- Full-flow spin-on oil filter with internal bypass
- Integral fuel filter with water separator
- Fuel warmer
- External in-line fuel strainer with clear bowl
- Stainless steel exhaust
- Stainless steel hinges and hardware
- Driver-side controls
- Large aluminum service access door with quick-release latch
- Battery access door
- Forklift pockets allow mounting from either side
- 12V DC maintenance-free battery
- Safety stop controls for low oil pressure, high water temperature
- Frame and sheet metal components powder-coated for durability
- Patented E-coat tube and fin radiator
- Large oil pan capacity extends running hours between oil changes
- Fuel gauge, color-coded for easy level identification from a distance
- DC ammeter
- Power output circuit breaker

- Preheat and Start/Run/Off switches
- Coolant overflow bottle
- Engine hourmeter
- 68-gallon (257-liter) integral fuel tank
- Operating instruction labels (English and Spanish)
- Maintenance and schematic labels
- Oil pressure and water temperature gauges
- Solid-state battery charger

Accessories and Options:

- FuelWise
- Auto Restart
- Four-point QuickMount™ installation system (with single captive bolts)
- Low coolant sensor
- 50-gallon (189-liter) integral fuel tank, available in aluminum or steel
- 80-gallon (303-liter) integral fuel tank
- CE certification
- TIR seals for detecting unauthorized access
- Outside mounted control box and additional unit service access door

Approximate Weights:

- 705 kg (1,555 lb.) with 50-gallon integral steel tank, less fuel
- 674 kg (1,485 lb.) with 50-gallon integral aluminum tank, less fuel
- 717 kg (1,580 lb.) with 68-gallon integral fuel tank, less fuel
- 710 kg (1,545 lb.) with 80-gallon integral aluminum tank, less fuel

North and South America

Carrier Transicold
Container Products Group
1095 Cranbury South
River Road, Suite 23
Jamesburg, NJ 08831 USA
Tel: +1-973-895-1353
Fax: +1-973-895-1356

Europe/Middle East/ Africa

Carrier Transicold
Limited
Pittsburghstraat 21
3047 BL Rotterdam
The Netherlands
Tel: +31-10-2380100
Fax: +31-10-2380142

Asia/Pacific

Carrier Transicold
Pte. Ltd.
251 Jalan Ahmad
Ibrahim
Singapore 629146
Tel: +65-6213-6388
Fax: +65-6862-5309

Asia/Pacific

Carrier Refrigeration
(Hong Kong) Ltd.
Unit A-C, 20/F
Tsuen Wan
International Centre
68 Wang Lung Street
Tsuen Wan, N.T.
Hong Kong
Tel: +852-288-00389
Fax: +852-288-00314

Japan

Toshiba Carrier
Transicold, Ltd.
14 Nihon Odori
Naka-Ku, Yokohama,
Japan
Tel: +81-45-664-6271
Fax: +81-45-664-6270

Australia

Carrier Refrigeration
Building A, Lot 302
Hill Road, Lidcombe
Sydney, NSW 2141
Australia
Tel: +61-2-9818-9700
Fax: +61-2-9810-4139



Carrier

A United Technologies Company

Carrier Transicold Division
Carrier Corporation
Container Products Group
P.O. Box 4805
Syracuse, NY 13221 USA

www.container.carrier.com

